

## Product Datasheet: 1500ml/min Silencer Series with BLDC Motor and Integrated Motor Control

All Diener pumps are customized to suit your requirements: the information below represents one of the possibilities...

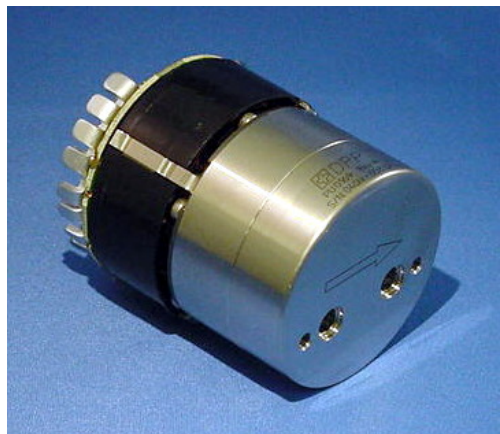

The Silencer series is everything a gear pump should be: simple, leak-free, chemically inert, reliable, and economical. It's manifold mounting simplifies the plumbing and reduces the installed cost in your system. A magnetic coupling ensures the pump will never leak and wetted materials are chosen to withstand a wide range of aggressive chemicals. The enhanced gears and shaft bearings have been optimized to ensure a long, trouble-free life and very low power consumption. And of course we manufacture every component using Diener's superior production techniques, resulting in a very high quality product at a relatively low cost.

- Magnetically Coupled: No seal leaks
- Low Power Consumption: Very little heat transfer to fluid
- Inert Construction Materials: Compatible with wide range of fluids
- Compact: BLDC motor is incorporated into the pump
- Extremely Quiet: Ideal for OEM equipment
- 24 volt BLDC motor: long life and maintenance-free
- Large diameter porting is ideal for higher viscosity fluids
- Integrated motor controller for simplified operation



is certified to  
ISO 9001:2008 / ISO 13485:2003

**Typical Performance Curve: Water at Room Temperature**

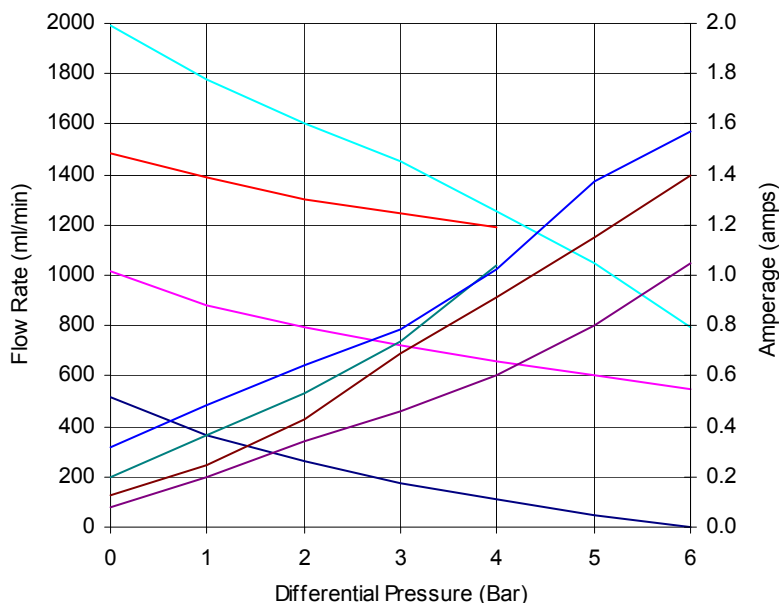

—	Flow: 1000rpm
—	Flow: 2000rpm
—	Flow: 3000rpm
—	Flow: Full Speed
—	Amps: 1000 rpm
—	Amps: 2000 rpm
—	Amps: 3000 rpm
—	Amps: Full Speed



### Specifications:

Performance:

Max. continuous pressure: 4 bar  
 Max. intermittent pressure: 6 bar  
 Max. static Case pressure: 20 bar  
 Inlet: Self-priming  
 Speed range: 300-4200 rpm  
 Fluid viscosity range: 0.3 to 1000 cps

Electrical:

Supply voltage: 24vdc  
 Rotation: Clockwise (see page 2)  
 BLDC controller: Integrated onto motor PC board  
 Max. current: 1.2 amps  
 Max. output power: 35 watts  
 5-pin Tyco/AMP connector

Temperature:

Fluid temperature range: 0-80°C  
 Ambient air temp. range: 0-60°C  
 Relative humidity range: 0-95% non-condensing

Construction:

316L or 303 stainless steel (body), PEEK® (gears), EPDM (o-ring)  
 Optional: PPS (gears), Teflon®, Silicone, Viton®, Kalrez® (o-rings)  
 Inlet/Outlet: Manifold mounted with o-ring glands to fit -008 o-ring  
 Marking: Permanent laser-mark identification for 100% traceability.  
 Mass: 0.6 kg

None of the information supplied by Diener Precision Pumps constitutes a warranty regarding product performance or use. Any information regarding performance or use is only offered as suggestion for investigation for use, based upon Diener Precision Pump's or other customer experience. DPP makes no warranties, expressed or implied, concerning the suitability or fitness of any of its products for any particular purpose. It is the responsibility of the customer to determine that the product is safe, lawful and technically suitable for the intended use. The disclosure of information herein is not a license to operate under, or a recommendation to infringe any patents.

**Product Datasheet: 1500ml/min Silencer Series  
with BLDC Motor and Integrated Motor Control**

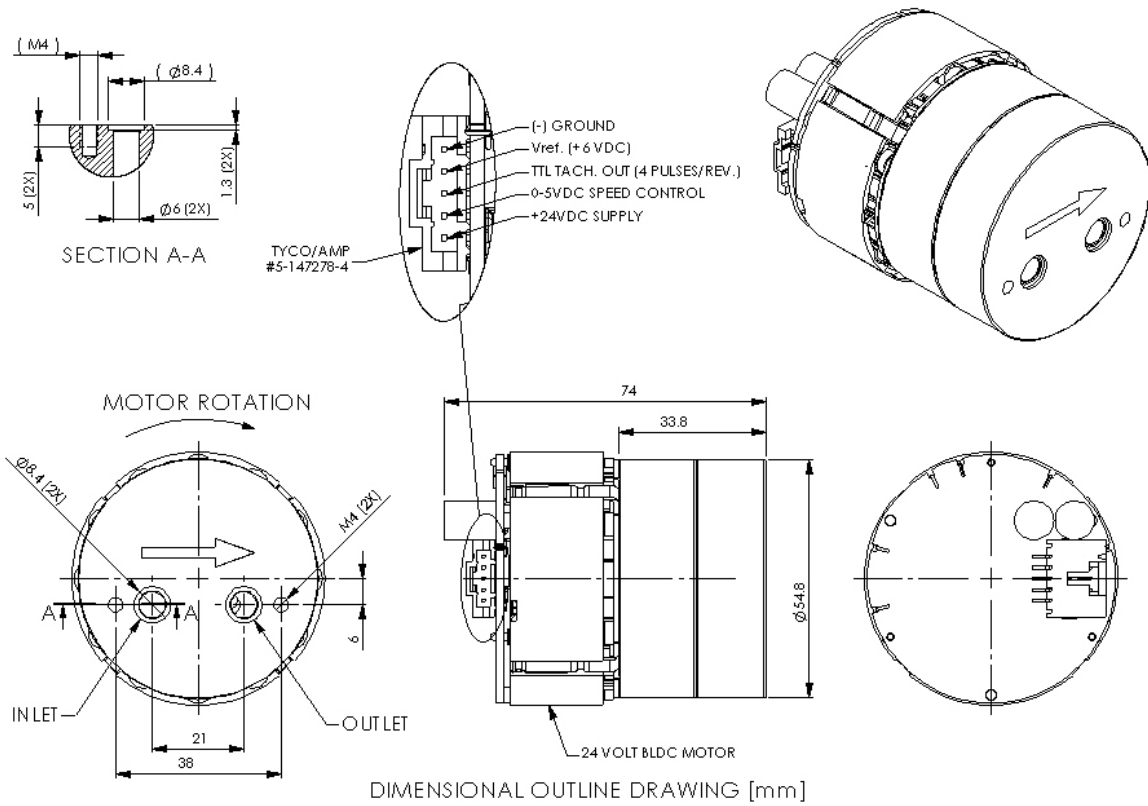

**Connection Information**

(Speed control ground must be common with motor power supply ground)

**Motor Control via External Speed Control Signal**

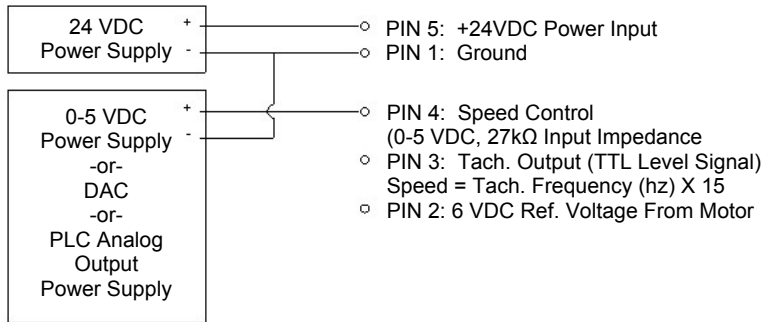

Photo above shows standard motor connector; photo below shows option wiring harness. The mating connector is a TYCO/AMP part no. 104257-4 with TYCO/AMP part no. 1-104480-4 pins (5 each).

**Motor Control via External Potentiometer**

